

Oxygen sensors and their use within Rebreathers

Author – Kevin Gurr

Date - 2013

Table of Contents

Oxygen sensors and their use within Rebreathers	1
History.....	2
Concept	2
Operating Principle	3
Concept Summary.....	4
Mechanical Construction	6
Sensor Construction	7
Electrical Construction.....	8
Electronic Functionality	8
Interfacing a Sensor to a Rebreather	10
A Typical Sensor Specification	11
Understanding a Sensor’s Response Time.....	13
Sensor Life Span	13
Failure Rate Actual Example	14
Humidity	14
Current Limiting	16
Using Oxygen Sensors in a Rebreather	16
Calibration.....	17
Storage and Sensor Life.	19
Rebreather Control systems	21
Golden rules	23

History

The oxygen sensor was invented in the 1960's.

The first use in a rebreather was by Walter Stark in the Electrolung. Development of the Electrolung came about through a chance meeting of John Kanwisher and Walter Stark aboard Ed Link's diving research vessel in the Bahamas in early 1968. Ed was trying out his new diver lock-out submarine 'Deep Diver' and had invited along several researchers with relevant interests. Walter was there to do some deep biological collecting and John was there to do heart rate/respiration measurements on divers using some new acoustical telemetry equipment he had developed. It turned out they had both been considering the feasibility of a mixed gas Closed Circuit rebreather (CCRB) using electronic sensors to control the Partial Pressure of Oxygen (PPO₂). Hence the Electrolung was born.

Oxygen sensors were developed as atmospheric pressure devices to measure up to 1 Standard Atmosphere (atm)¹ or 100% oxygen at sea level. Oxygen sensors have proved to be very reliable for over 40 years. There are in excess of 20,000 in use within the UK at any one time alone. In the medical industry many life support system; anesthetic machine, ventilator, incubator has at least one and sometimes two.

There are now several manufacturers of oxygen sensors globally.

Concept

The Oxygen sensor is comprised of a galvanic fuel cell (the 'wet element') and an electronics package. Combined they make an Oxygen sensor.

The Oxygen cell is an electro-chemical device. Possibly the best way to think of it is that it represents a battery. The battery is a complete electro-chemical device and is capable of providing a maximum voltage and current based on its design specification. Over time that output reduces (decays) and eventually falls to zero.

However, unlike the battery, the Oxygen cell is initially inactive and requires an additional catalyst (Oxygen) to start the chemical reaction and hence produce an electrical output. The time over which the output of an Oxygen cell decays is primarily a function of the amount of Oxygen it is exposed to.

¹ 101325 Pa ("Pascal's") or 1013.25 mill bars or hectopascals. It is equivalent to 760 mmHg (torr), 29.92 inHg, 14.696 psi

Operating Principle

Oxygen (O₂) is a gas. It is vital for metabolism in most living organisms and is a potent oxidizing agent. When exposed to the chemical elements within an oxygen sensor it produces a chemical reaction. The chemical elements typically found in an oxygen cell are;

Lead (Pb) – the anode

Platinum (Pt) – the cathode

Potassium hydroxide (KOH) – the electrolyte

Oxygen in contact with the cathode is reduced to hydroxyl ions, with a balancing reaction of lead oxidation at the anode. The reaction equations are:

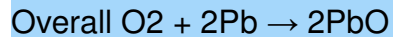
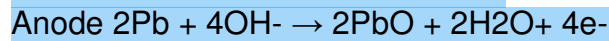
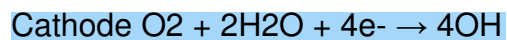

The result is that Oxygen cells generate an electrical current (not a voltage), which is proportional to the rate of oxygen consumption². This current is easily measured by placing a load resistor between the cathode and the anode (the 2 pins on the 'wet element' of an oxygen cell) and measuring the resultant voltage drop across the resistor.

The anode is made out of lead but is not solid. It is a collection of small balls of lead compressed into a donought. This has the effect of evening out the usage of lead throughout the sensors life. During the electrochemical reaction the Oxygen converts the lead to lead oxide, which in turn generates the electrical current coming out of the sensor.

As the lead is used, the surface area of the anode reduces, therefore the electrical output falls. The use of bonded lead (the lead balls are compressed so 'stick' together) helps reduce this effect therefore maintaining a fairly constant output until the end of the sensors life. Although the sensor exhibits a measurable decrease in output until the end of its life, it is not a continuous linear reduction

Most galvanic oxygen sensors use a perforated and convex gold or platinum plated (or another noble metal) sintered steel cathode. The cathode lets the electrolyte through and keeps the top of the cathode continuously wet (with electrolyte) which ensures minimal internal resistance during the oxygen sensing action. This combined with the oxidise-able lead anode completes the electrochemical reaction. As mentioned the sensor's lifetime is a function of the amount of lead remaining in the anode and as the output remains nearly constant until most of the lead is oxidised, the oxygen sensor's 'end of life' is difficult to predict.

The most common electrolyte used in oxygen sensors is potassium hydroxide (KOH) as lead oxidation is best controlled in an electrolyte with a pH between

² Faradays law

10 and 12 although weak acids can also be used.

As lead oxidises the oxide occupies more volume than pure lead, so the combined anode and electrolyte volume inside the oxygen sensor expands. If the sensor is not correctly designed, then the internal pressure can rise and cause the sensor to become inaccurate and it may eventually damage the device. The use of a flexible rear membrane helps equalise the volume.

A partial pressure sensor design is needed for use in a rebreather. A 'Teflon like' solid polymer membrane is used through which gas diffuses into the sensor. A hydrophobic membrane is added to help keep the Teflon membrane clear of condensation. The PPO₂ pressure gradient across the membrane is linearly proportional to the partial pressure of the oxygen on both sides of the membrane³. The rate of diffusion is also highly temperature dependant. The gas must first pass through this membrane hence the membrane in conjunction with the electrolyte between the membrane and the cathode controls the response time of the sensor. The membrane is set at manufacture and the speed at which gases pass through it cannot vary unless the membrane ages or is affected by condensation or contamination.

Water on the surface of the membrane acts as a barrier, the Oxygen will move through the water at a certain rate then through the membrane into the sensor.

Consumption of oxygen at the cathode maintains a partial pressure gradient across the membrane which is directly proportional to the ambient PPO₂. If the cell is working correctly the cell output will rise in direct proportion of the ambient PPO₂.

A simple example being;

An oxygen sensor reads 10mv in air at sea level (PPO₂ = 0.20945 atm). If the PPO₂ is raised to 1.0 atm then the sensor output rises to 47.74mv.

$$1.0/0.20945 = 4.774$$

$$4.774 \times 10\text{mv} = 47.74\text{mv}$$

Concept Summary

Rebreather galvanic oxygen sensors exhibit the following characteristics:

1. At a constant oxygen concentration (% of oxygen) the output will continue to rise linearly with increasing ambient pressure (even though the percentage of oxygen is not changing). Hence the output varies linearly with PPO₂.
2. Any change in atmospheric pressure linearly affects the oxygen partial pressure hence the sensors are linearly dependent on ambient pressure as well.

³ Fick's Law

3. Since the gas must diffuse through a solid polymer membrane, the rate of diffusion is dependent not only on the gas partial pressure but also on the diffusivity of the membrane.
 - a. The diffusivity of a polymer membrane is highly temperature dependent, typically 2.5%/C; this is corrected by using a Negative Temperature Coefficient (NTC) thermistor sensor inside the body of the oxygen sensor to compensate for temperature changes.
 - b. During thermal transients (rapid thermal changes) the membrane diffusivity and the NTC thermistor may not be in phase and significant PPO₂ changes can result.
4. Diffusion through a polymer membrane is relatively slow and while they will respond rapidly (within 10 seconds) to approximately 90% of the oxygen partial pressure the remaining 10% can take 20 to 60 minutes to fully register. The diffusion rate is also a function of condensate on the membrane.
5. Partial pressure sensors are linearly dependent on pressure. In a rebreather application the sensor must be 'balanced' i.e. ambient pressure is allowed into both ends of the device. If one side were closed to ambient pressure then the output would rise with both pressure (depth) and PPO₂ rather than just PPO₂ as in the balanced device.

In summary; partial pressure sensors respond linearly to changes in PPO₂, require temperature compensation, have a slow response time and if designed correctly (balanced) show no change in output when exposed to ambient pressure changes. They are unaffected by most other gases except Chlorine and high levels of CO₂ (much higher than physiological levels experienced in rebreather systems).

In a known environment and within the devices operational limits, they are very stable and reliable. They have a 'life span' (primarily as a function of the oxygen level they are exposed to).

If they are operated outside of their design specification they can become unreliable and inaccurate.

Mechanical Construction

The sensors case is normally constructed of a plastic such as polythene. In order for the electrolyte to remain within the sensor, two solid polymer membranes are placed either side of the anode/cathode/electrolyte assembly.



Figure 1

Sensor and sensor with the top cover removed showing the electrical connection and Printed Circuit Board (PCB)

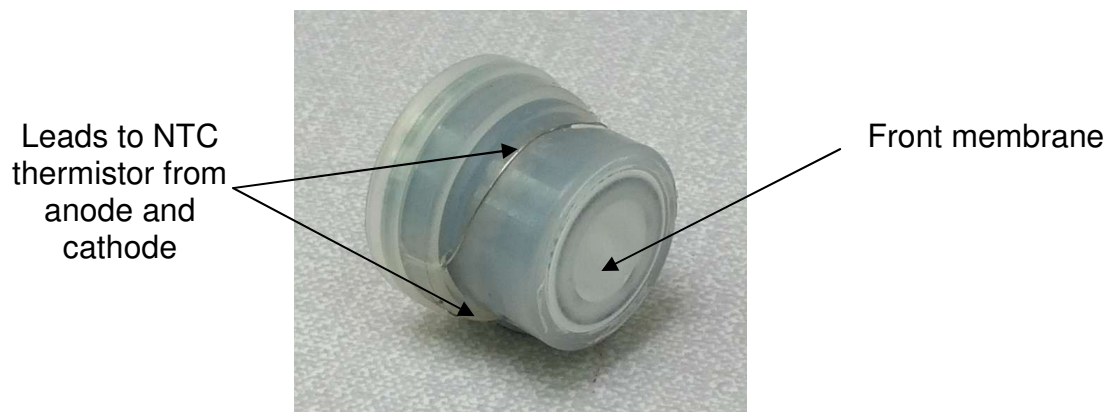

Figure 2

Sensor with front and rear cover removed

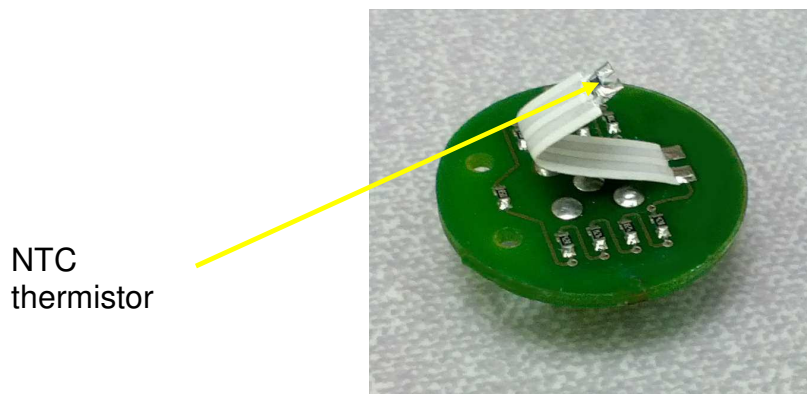

Figure 3

Electronic printed circuit board (PCB) showing resistors and NTC thermistor

The sensor's case is normally constructed of a plastic such as polythene. In order for the electrolyte to remain within the sensor, two solid polymer membranes are placed either side of the anode/cathode/electrolyte assembly.

Sensor Construction

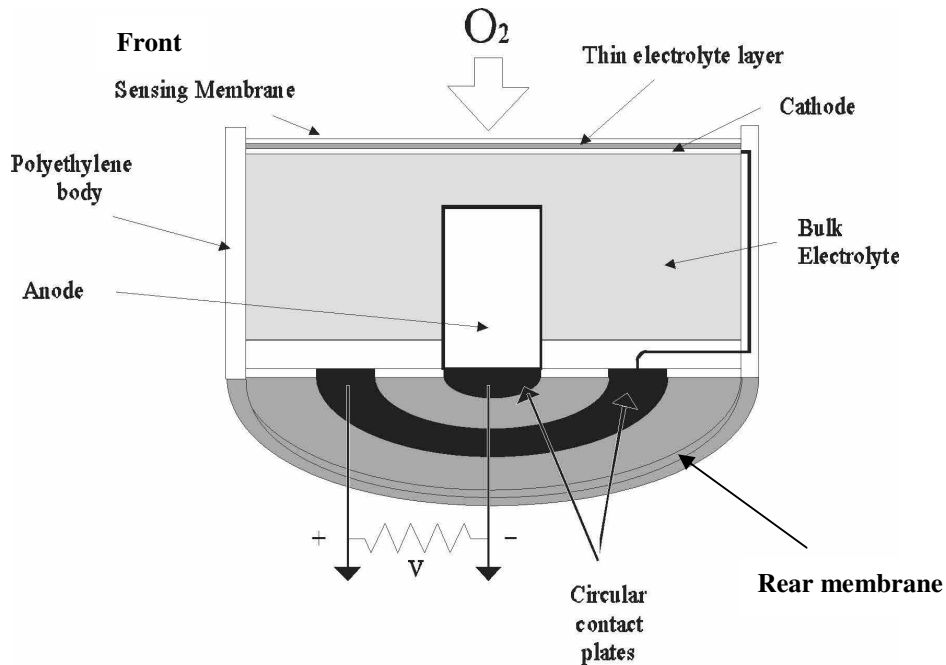

Figure 4
Sensor Cross Section

It is important that this rear membrane is not occluded. In order for the sensor to work correctly the volume needs to be constant otherwise the pressure generated in the sensor would be displayed as an additional output. If you look at the back of a diving sensor you will see two small holes in the PCB. These allow the front & rear membranes to equalize and hence maintain a constant volume within the sensor.

On some sensors a small hole is also drilled in the case near the connector, this must also be open (dependant on the connector type fitted as some can create a seal into the membrane).

The cathode is below the front face membrane from which it is separated by a thin electrolyte gap. The cathode is a sintered steel grid plated with noble metal such as gold, silver or rhodium.

The anode is constructed of lead balls. Both the anode and the cathode have a fine wire attached in order to connect to the interfacing electrical circuit.

On the rear of the sensor is a small printed circuit board (PCB) which carries the electronic components (the temperature compensation network). This board is conformal⁴ coated.

⁴ Covered in a waterproof coating

Electrical Construction

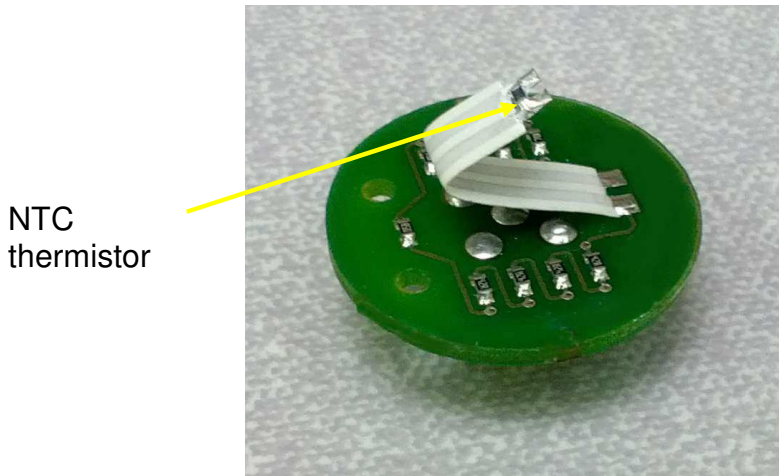

Figure 5
PCB showing resistors and NTC thermistor

On the PCB are a series of resistors and a NTC thermistor. The NTC thermistor is a resistor that changes its resistance with temperature. The NTC thermistor (part of the temperature compensation network) is placed as near to the rear membrane as possible so that it registers the temperature of the electrolyte.

In addition there are two wires that link to the electrical connector mounted on the PCB.

Electronic Functionality

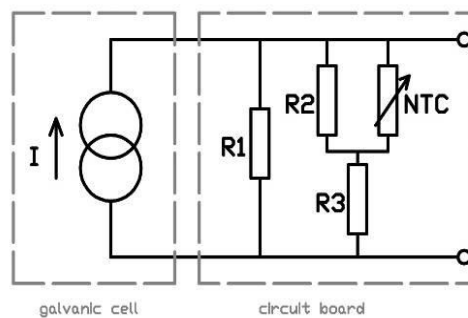

Figure 6
Typical circuit

As discussed we know that the electrical output of the sensor will vary by approximately by 2.5% per degree C rise in temperature therefore, a temperature compensation method has to be used.

The PCB layout consists of a resistor network with three normal resistors, (R1, R2 and R3) and one temperature dependent resistor, or 'NTC

thermistor'. The NTC thermistor has a Negative Temperature Coefficient (NTC). This means that the value of that resistor (measured in Ohms) will decrease when the temperature increases.

From the above schematic we can see that the sensor is separated into two sections. On the left we have the galvanic cell, (the current source) the 'wet element', next to it the resistor network (R1, R2, R3, NTC).

Using Ohm's Law and as the resistance of the NTC decreases with increasing temperature the total resistance of the network will also decrease.

There is a 'virtual' internal series (in line with the current generator) load resistor caused by the various impedances of the components and mechanisms inside the sensor i.e. the surface area of the lead anode, the resistance of the internal connecting wires and the transfer of electrons and ions through the electrolyte.

Assuming a constant PPO₂, we know from previous discussions that the current supplied by the galvanic sensor increases when the temperature increases and that this must be corrected for. This is achieved using the resistor network.

Ohm's Law states that the voltage measured across a resistor (network) equals resistance multiplied by current ($V=I \times R$)

As the total resistance (R) of the network will vary with temperature (due to the NTC thermistor) then the voltage (V) remains constant. So the rise in output caused by a temperature is corrected for using the resistor network.

Using a system like this, the sensors can be made to correct for rises in temperature over a fairly wide range (typically 0-40/50 degrees C). That is to say they will provide a linear rise in voltage for a rising PPO₂ over the compensated temperature range. Limited by the NTC thermistor characteristics

Interfacing a Sensor to a Rebreather

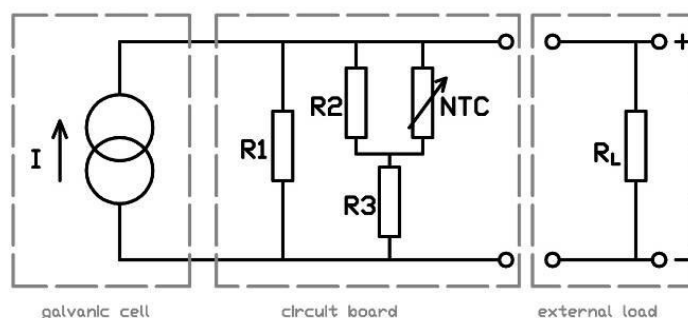

Figure 7
Sensor Schematic

From Figure 7 we can see that R_L (the External Load Resistor) has been added. The voltage the rebreather uses to drive its' electronics is measured across this resistor. This load resistor is not positioned within the sensor but is inside the measuring electronics.

As there is normally some distance between the sensor and the electronics (which often involves cables and connectors), this load resistor helps reduce the effects of external influences on the cable (electrical noise etc.). This resistor ensures a very small current is supplied along the connecting cable that can then be measured as a voltage across the load resistor.

This resistor is typically a minimum value of 10.000 Ohms. As this value is much larger than the value of the sensors resistor network (often 10 times larger), over 98% of the sensors current goes through the resistor network and only a very small portion through the load resistor

A Typical Sensor Specification

Specification	Definition
Output 8-13mV in Air at 25°C @ sea level	The sensor (when new) could display 8-13mv in air at 25°C @ sea level
Maximum output in 100% oxygen at depth at 25°C = 175mv (equivalent to 3.5 atm).	The maximum PPO2 the sensor can display.
Range 0-100% Oxygen	The sensor can measure between 0 and 100% oxygen
Accuracy +/- 1% of FSD ⁵ at a constant Temperature and Pressure	If the ambient temperature is within the compensation range and the PPO2 remains constant then the maximum reading the sensor will allow will only have a +/- 1% error. E.g. At 2.0 atm the error could be +/- 0.02 atm. Otherwise known as the sensors Linearity
Response time < 6 seconds for 90% of final value	When a fixed PPO2 is applied to the sensor the sensor will show 90% of that value in under 6 seconds.
Offset Less than 0.5% of oxygen equivalent at 25°C in zero gas after 36 seconds	At 25°C, after instantly reducing the PPO2 from a nominal value to 0.0 atm then the actual reading within 36 seconds could be 0.5% of the start value. E.g. if the PPO2 is reduced from 2.0 atm to 0.0 atm then after 36 seconds the measured PPO2 could still be 0.1 atm.
Humidity 0-99% Relative Humidity (RH) Non condensing	The sensor will function to specification in up to 99% relative humidity providing water does not condense (form droplets).
Operating Temperature range 0°C to 50°C	The sensor will function to specification from 0°C – 50°C.
Storage temperature 0°C to 50°C	The sensor can be stored at temperatures from 0°C to 50°C without damage.
Average expected life 36 months in air @ 25°C and 50% RH	The sensor will 'fail' ⁶ after 36 months when used in air (21% oxygen ⁷) @ 25°C with 50% relative humidity (non condensing).
Load required = 10K ohms	To avoid drawing excessive current from the sensor the electronics it

⁵ FSD – Full Scale Deflection. The maximum value the sensor can display

⁶ See Failure Modes section

⁷ Approximation for simplicity

	interfaces to must have a minimum of a 10k Ohms input impedance ⁸ .
Temperature compensation: +/-5% of FSD over the operating temperature range.	If a step change in temperature is applied from the minimum to the maximum allowed (0 to 50 degrees C), the PPO2 will remain accurate within 5%. E.g. at 2.0 atm and a stabilised 50 degrees C the PPO2 would read 2.0 atm, if the temperature is then rapidly changed to 0 degrees C, the PPO2 would be within +/- 5%.
Worst case tracking error (within the first hour after a maximum temperature step) is +/- 5% to 7.5% (gas samples must be brought to ambient temperature) percent readout is only within +/-1% at constant pressure. (e.g. A 10% increase in pressure will result in a 10% increase in readout)	<p>With a step change in temperature (to a maximum of 50 degrees C) it can take up to 20 minutes for the sensor to fully react (for the reasons already defined). During this transition the output could be in error by as much +/- 5% to +/-7.5% depending on the manufacturers specification.</p> <p>In a rebreather, the temperature step can be large dependant on the storage temperature prior to use. At a setpoint of 1.2 with a +7.5% error would equate to a PO2 reading of 1.29. Not in its self a major problem but for deep/long dives, it highlights the importance of letting the sensors get close to the canister operating temperature prior to a calibration.</p>

⁸ The input impedance is the resistance at the input of the electronics used to measure the signal from the sensor.

Understanding a Sensor's Response Time

Oxygen sensors respond very quickly to a change in PPO₂. As per the specification, a step change test is referenced.

The sensor is first exposed to dry air (20.9% oxygen) for a short period then 100% oxygen is applied. The sensor will display a voltage equal to 90% of the gas it is measuring (100% oxygen) in under 6 seconds. The remaining 10% of the measurement can take up to a minute and 10-60 minutes for the last 1mV. This is obviously a large change and smaller changes from one level to another are relatively rapid.

So why does the sensor take time to respond? As mentioned, firstly the gas has to pass through the membrane. Secondly it must diffuse into the electrolyte which is governed by Fick's Law. If the membrane becomes damaged/contaminated in anyway or is moisture laden, all of these issues will affect the response time. In addition the age of the sensor affects the lead surface area which again can affect response time.

Sensor Life Span

The life of a sensor depends on many things including user abuse and theoretically it can be calculated. Ultimately it depends on the amount of lead remaining in the anode and the maximum PPO₂ you are measuring.

Assuming a new sensor is capable of a PPO₂ limit of 3.5 this is a reflection of the maximum current it can supply. As the sensor ages then this 'current limit' reduces and the same sensor after a year may only be able to indicate a PPO₂ of 1.5 atm.

This leads to the question of when sensors should be changed. The sensors aging process (ignoring user abuse), as we have seen, is primarily a function of the PPO₂ it is subjected to (a sensor left in 100% oxygen will have a shorter life span than one left in 21% oxygen). The higher PPO₂ reduces the anode faster. However because of improving the manufacturing processes, if three sensors were exposed to exactly the same environment (as in a rebreather) for a prolonged period, they could conceivably all fail within a reasonably short time span.

In other words 'staggering' sensor change-outs can be adopted as a useful technique but there is no data to suggest that this reduces the probability of failure significantly on a dive. **What is more important is the overall change-out period.**

The normal expected life of a sensor which would be used in a rebreather (a fast reacting sensor) is about 30 weeks in 100% oxygen at the surface⁹ (1.0 atm). Use in a rebreather environment will reduce this but by how much is difficult to estimate.

⁹ Dry air at 25°C

Manufacturing data has shown that if sensors (used in a rebreather) are changed every calendar 12-18 months (a calendar date 18 months from when they were installed not 18 dive-months of time) then failure rates are extremely low per sensor and multi-sensor failure rates are very low. For most people this equates to a seasons diving.

Failure Rate Actual Example

A sensor manufacturer has reported the following returns rate (not failure rate) on a sample set of 10,000 oxygen sensors, all of which were used in rebreathers.

Total returns were reported at 0.35%.

On analysis 0.19% had no fault found or were a result of excessive moisture (flooding). Some of these sensors exhibited salt crystals and/or absorbent dust on the membranes.

Removing the flooded sensors from the evaluation meant that 0.16% were logged as actual faulty sensors, 6 of which was due to galvanic corrosion of the output connector washer as a result of substandard vendor materials (the sensors still functioned within specification).

Therefore, removing these sensors from the figures, we find an actual failure rate of 0.10% for approximate ages between 51 and 208 days.

Some anecdotal historic evidence supports the occurrence of accelerating failure rates. This is believed to be temperature (over or under/freezing temperature) related and is the main cause of early sensor exhaustion/failure.

Humidity

Relative Humidity (ϕ) abbreviated as RH, of an air-water mixture is defined as the ratio of the partial pressure of water vapour (H_2O) (e_w) in the mixture to the saturated vapour pressure of water (e_w^*) at a given temperature.

Relative humidity is normally expressed as a percentage and is calculated by using the following equation:

$$RH\% (\phi) = \frac{e_w}{e_w^*} \times 100$$

The notion of air holding water vapour is presented to describe the concept of relative humidity. This, however, is a misconception. Air is a mixture of gases (nitrogen, oxygen, argon, water vapour, and other gases) and as such the

constituents of the mixture simply act as a transporter of water in its gaseous form (water vapour).

RH is defined in terms of only the physical properties of water and thus is unrelated to the notion of air holding water. In fact, an air-less volume can contain water vapour and therefore the humidity of this volume can be readily determined.

Above 100% RH and water may begin to condense (droplets form).

A RH change can be as a result of change in system temperature, a change in the volume of the system, or change in both of these system properties.

Condensation in a rebreather commonly occurs when water vapour is cooled to its saturation limit or 'dew point' and the molecular density of water in the gas phase reaches its maximal threshold. The dew point is the temperature below which the water vapour in a volume of humid air at a given constant barometric pressure will condense into liquid water (at the same rate at which it evaporates). Condensed water is often called dew or condensate when it forms on a solid surface.

The dew point is a water-to-air saturation temperature. The dew point is associated with relative humidity. A high relative humidity indicates that the dew point is closer to the current air temperature. Relative humidity of 100% indicates the dew point is equal to the current temperature and that the air is maximally saturated with water. When the dew point remains constant and temperature increases, relative humidity decreases.

An example being that condensate will form on the cold wall of a rebreather canister that has gas flowing through it. Also if the body of the oxygen sensor is attached to an area of the rebreather that is thermally conductive and hence possibly cold during use (due to external water temperature) then condensate will form on or close to the sensor and may affect the diffusion across the membrane if it collects there.

In a rebreather, oxygen sensors are always exposed to humidity. This phenomenon becomes important during calibration. As we have seen, moisture on the membrane slows diffusion of the gas into the sensor.

For this reason the rebreather control system (when calibrating) needs to be given time to take the required measurements. If the sensors are dry and the control system is set to calibrate quickly, the calibration result will be different if the sensors were wet (and the system calibrates quickly).

Generally speaking as the sensors will spend most of their life in a humid environment they should be calibrated in the same humid environment.

Sensors that are calibrated when dry will exhibit a small error in use within the rebreather.

The sensor has a hydrophobic membrane added and although it can be washed and dried for surface applications, for life-support it must be replaced

if it suffers flooding. The membrane, being hydrophobic means that it can accept a small pressure differential across it before it allows water to pass through it. The Teflon membrane allows some humidity to pass through which is why the electrolyte can evaporate in a dry atmosphere. The additional hydrophobic membrane stops moisture passing through. If the membrane becomes encrusted with salt or CO₂ absorbent, the contaminant can be gently removed with fresh water (avoid using a pressurised spray or touching the membrane) and dried.

Normally excessive moisture can be shaken off if the sensor is turned upside down. The biggest damage is by sea water coming into contact with the temperature compensation components. A paper tissue if used carefully can be used to suck moisture off the sensor membrane. The safest advice is if the sensor has become flooded with sea water then it should be replaced.

Current Limiting

The output of the sensor is controlled by the amount of current that can pass out of the sensor for any given partial pressure of oxygen. As discussed the size and surface area of the anode control the internal impedance (resistance) and as the anode is consumed and the amount of lead decreases, the internal impedance increases hence reducing the maximum amount of current the sensor can supply and therefore the voltage measured across the internal load resistor. A new sensor is also current limited for the same reasons and typically will limit around 175mV or (assuming 10mv is 0.21 atm) 3.675 atm.

Sensors should not be tested above 2.0 atm O₂. Also care is required when using pressure testers to ensure the manufactures instructions are followed to the letter. Slight errors are accentuated by pressure as are stabilisation times between readings.

So current limiting affects us as divers because as the anode reduces it cannot provide enough current and the reading measured 'peaks'. The danger is that while at the surface during calibration against 100% oxygen, the sensor may read 1.0 atm but when exposed to a higher PPO₂ whilst diving (e.g. 1.3 atm), it may only be able to supply enough current to indicate a lower PPO₂ (e.g. 1.2 atm). Not only will the diver be unaware of this, but if the limited cell output is below the PPO₂ set point, then the rebreather could also continue to add oxygen even though the loop PPO₂ is rising to dangerously high levels. rebreather designs and diving procedures have been developed to minimise the risk of such events

Using Oxygen Sensors in a Rebreather

As we have seen (aside from age) temperature and humidity can have major affects on the performance of an oxygen sensor.

In respect of temperature, first it is apparent that if the oxygen sensor is temperature compensated from 0 to 40°C then the position of those sensors within the rebreather should ensure that they are never exposed to more than 40°C throughout transport, calibration or a dive(s). Under CE EN14143 the PPO₂ tracking, test which measures the accuracy of the sensors over a time

period, will confirm if this design requirement is being met during a dive (e.g. if due to location in the rebreather the sensors are not exposed to excessive moisture or temperature). As a designer, without conducting this or similar tests, it will not be possible to assess if the sensors are being 'stressed'. The CE test also tests for safe operation after storage at a range of storage temperatures which should obviously not be exceeded and should be specified by the manufacturer.

Excessive temperatures can also damage the sensors by evaporating the electrolyte, that is this why this test and ensuring storage temperatures are also not exceeded, are vital to maintain 'sensor health' and accuracy while in use.

If the bulk electrolyte evaporates bubbles may be formed in the electrolyte and may manifest as erratic readings.

If the electrolyte layer between the membrane and the cathode evaporates or leaks it usually displays itself as a higher than normal output. I.e. The molecules of oxygen are transported to the cathode faster. This is why it is useful to maintain a record of sensor mg's in air. The output should always decay and never rise but this is partially dependant on atmospheric pressure and temperature.

Humidity specifications for sensors vary. Some reference a maximum relative humidity of 50% and some 99%. Air leaving the mouth has an approximate temperature of 35°C and 95% RH. This means that the sensors in a rebreather are normally exposed to at least this RH.

Oxygen sensors prefer a reasonably stable temperature and humidity environment. In some rebreathers this is not the case and as discussed the relative position of the sensors can also cause water vapour to condense and form droplets and affect the diffusion across the sensors membrane.

As temperature and pressure also affect RH and as these are changing all the time in a re-breather and because the sensors (when multiple sensors are used) will be in slightly different positions relative to gas flow, they will always exhibit slightly different readings. However this variation is acceptable and dealt with within the control system electronics.

Calibration

A healthy and well designed sensor will calibrate accurately in air at the surface. It will then accurately read elevated PPO₂'s correctly because it is linear in its response to changing PPO₂'s. This assumes the same atmospheric pressure temperature and humidity (STP).

Because of this linearity it need only be calibrated at one point, either dry air or oxygen are preferred. However as we have seen previously for as an accurate calibration as possible the calibration should take place once the absorbent canister has reached operating temperature (and humidity) and once the sensors has fully reacted to the change (up to 20 minutes). Without

allowing for this, as we have seen, a 1.2 setpoint on a rebreather could be registered as 1.29 as a worst case.

However if the sensor is aging and is current limiting, then it may calibrate correctly in air (or even 100% oxygen at the surface) but will not accurately measure elevated PPO2's (above it's current limiting atm) at depth.

Electronic control rebreathers (and any PPO2 display) have a method for converting a sensors output (in air or 100% oxygen) during the calibration process to compensate for degradation of the sensors (reduction of output as a function of age). This is commonly called the calibration routine and is expressed in the following example;

- Sensor A has a 10mv output when exposed to sea level air. The calibration system is activated and the PPO2 displayed on screen is 0.21. When the sensor is exposed to 100% sea level oxygen it now reads 1.0 atm and its mv reading is 47.6mv ($1/0.21 = 4.76$. $4.76 \times 10\text{mv} = 47.6\text{mv}$)
- Sensor B has a 13mv output when exposed to sea level air. The calibration system is activated and the PPO2 displayed on screen is 0.21. When the sensor is exposed to 100% sea level oxygen it now reads 1.0 atm but its mv reading is 47.6mv ($1/0.21 = 4.76$. $4.76 \times 13\text{mv} = 61.9\text{mv}$).

Hence both read 0.21 in air and both read 1.0 in 100% oxygen. If sensor B is now installed into sensor A's position (and hence calibrated input) then the reading for sensor B in air would be 0.27 atm and in 100% oxygen would be 1.30 atm.

In summary, as the sensor ages then the reduction of output is corrected for by the calibration system and while a sensor may appear to be accurate at the surface (as the calibration system 'masks' the loss of output) it may still current limit at depth.

One way to test for current limiting is obviously to elevate the PPO2 above 1.0 and preferably to the required operating PPO2 of the rebreather. This can be achieved by submerging and performing a 100% oxygen flush of the rebreather at a safe depth (maximum 6m). If the PPO2 stabilises at or near 1.6 atm (+/- 0.1) there is then reasonable confidence that current limiting will not occur during the dive and providing the sensors are not be adversely affected by moisture or temperature during the dive. This combined with the prescribed sensor change-out period will significantly reduce the probability of current limiting becoming an issue.

A Diluent flush at depth, where the Diluent PPO2 is also above the rebreathers Setpoint will also provide the same confirmation.

In addition a Diluent flush must be conducted when any sensors reading is suspected to be in error. Some rebreathers automatically disable what they

consider to be 'rogue' sensors and some allow the decision to be made manually. Both systems must be confirmed with a Diluent flush.

As discussed, sensors are relatively linear in their response to increasing PPO₂ (in a stable environment). This linearity has an upper limit (of PPO₂) after which they become non-linear. As the sensor ages this upper limit reduces and a sensor that was linear to 3.0 atm, with time, may now only be linear to 2.0 atm.

This is very rarely a problem especially when sensors are changed every 18 months.

Storage and Sensor Life.

The production date of a sensor is normally printed on the sensors and can be expressed using two common methods;

1. Three (or four) numbers where the first (or first two) indicate the last number of the production year, and two other numbers that show the month
 - a. (example: 1205: 5th month of 2012, or May 2012)
2. A letter followed by a number(s), where the letter indicates the month, and the number the last number of the year
 - a. (example: A12 : January 2012)

Oxygen sensors do not come from the manufacturer stored in bags filled with inert gas or a vacuum. They do come in bags that once sealed allow the oxygen level in the bag to be depleted by the sensor thus slowly reducing the sensors output until all the oxygen is exhausted.

If an oxygen sensor is staved of oxygen it will almost stop providing an output as the chemical reaction is inhibited (but this can take a long time).

When they are removed from the bag they need time to activate and start responding to oxygen. Although they will give what may seem to be a reasonable output quite quickly, it is best to allow 24 hours of exposure to air for them to become fully responsive. Two hours (exposure to air) should be the minimum time before a sensor is used in a rebreather. If the output is still problematical then the sensor should be exposed to 100% oxygen for 2-3 minutes.

The storage temperature specification of the sensor is important. If they are stored in a hot and dry heat then evaporation of the electrolyte can result. Sensors are best stored within the rebreather after any condensed moisture has been removed.

Sensors are often supplied in a membrane shipping bag. A new sensor's life expectancy is 142 weeks in air or 30 weeks in 100% oxygen¹⁰. After 1 year in a bag this falls to approximately 28.5 weeks equivalent to a 5% reduction.

Therefore all sensors have a 'shelf life' when sealed in their shipping bags. In most cases this is two years. If the sensor has not been used within this period it must be discarded. Shelf life is a function of storage temperature. Temperatures outside of the manufacturer's specification will reduce the life.

If sensors are stored in 100% airtight bags for a long period, deactivation of the cathode may result and the sensor may not recover or may need 100% oxygen to recover.

As a general rule after 6 months exposed to 100% Oxygen the output of the sensor can be expected to reduce by 5mV from a starting point of 50mV in 100% Oxygen.

In a good sensor design, once the sensor is showing a loss of substantially more than 10% of its starting voltage say 13%-15%, then it should be changed. In the above example where a sensor started at 50mv in Oxygen then it should be changed when the same exposure reaches 45mv.

Historical evidence of sensor use in rebreathers indicates that a maximum change-out period of 18 months¹¹ should be adhered to.

¹⁰ 2013 mbar @25°C dry gas

¹¹ Manufacturer dependant

Rebreather Control systems

Premise

Commercially available rebreathers comprise of two main elements of the oxygen sensor and PO₂ control system;

1. An amplifier system to interface the sensors to the electronics.
2. An electronic 'voting logic' system

Both these systems combined determine the PPO₂ within the breathing loop based on amplifying the signal then adding the three sensor values together and dividing the total value by three.

The amplifiers (and subsequent software interface) must be designed so that they themselves provide a linear response to the oxygen sensors linear response to PO₂. The electronics must be able to adjust gain and offset parameters to (put basically) ensure that zero PO₂ is zero on a display and 2.0 PO₂ is 2.0 on a display. The electronics must also be temperature compensated over the expected ambient range.

With regard to the voting logic element, this is allowed to happen providing the readings from the sensors fall within the criteria of the voting system. In a simplistic system a typical example of voting rules would be;

1. If two sensors are within +/-0.2 atm of the rebreathers controlling Setpoint and a third sensor is reading >+/- 0.2 atm away from that Setpoint, then the third sensor will be removed from the voting logic and averaging will take place on the two 'good' sensors. Thus oxygen injection is now based on the average from the two sensors.
2. If all three sensors are >+/- 0.2 from Setpoint then all three sensors will still be used in the averaging.

In some rebreather system there are various other (more complicated) rules referencing 'very high' or 'very low' sensor readings and their subsequent disabling/enabling but the above expresses the basic logic for most systems.

In a single gas system (such as an electronically controlled single gas rebreather), if using the basic logic the average cannot be resolved, then the system has the option to ignore all the sensors and enter a 'fail-safe' mode whereby gas is injected at a rate to compensate for a typical metabolic usage of oxygen and thus maintain a life-supporting gas mix while alarming for a closed circuit bailout ascent to be undertaken.

Oxygen Sensor Failure Modes

In summary there are failure modes for oxygen sensors that can mean that the PPO₂ reading becomes near-static even though the PPO₂ in the

breathing loop is rising. This can become potentially hazardous to the diver as in this instance the Setpoint controller would continue to inject gas¹².

Example

Two sensors become static at >-0.2 from the Setpoint, i.e. they are reading low compared to Setpoint. Initially averaging will take place over the three sensors and because the average PPO2 will be below Setpoint, oxygen will be added to the breathing loop. At some point the third (good) sensor will start to read high and will be removed from the averaging in accordance with the voting logic rules. At this instance the averaging reverts back to the two static sensors (which are reading low compared to Setpoint) and the oxygen injection continues until an unsafe PPO2 is in the breathing loop.

It is clear from examples recorded in the field that this sensor failure mode (although primarily associated with inadequate maintenance by the user) can occur.

Although some rebreathers provide additional alarms when a sensor(s) is significantly different to the others and will warn the diver to perform an emergency procedure (such as adding Diluent to flush a known PPO2 over the sensors) and hence 'manually' verify the validity of the voting logics decision (and even disable erroneous sensors¹³), these alarms can be ignored.

¹² Reference Item 1 in the list on this page

¹³ Ref. Sentinel rebreather – Manual Sensor disable function

Golden rules

1. Change oxygen sensors every 12-18 calendar months once opened
2. Do not use sensors that have been stored for over two years
3. Do not use medical, industrial or automotive sensors in a rebreather
4. Only use a sensor designed and tested for use with your rebreather
5. Do not store sensors in air tight bags
6. Do not store sensors in high PPO₂'s for extended periods (+24 hours)
7. Do not store sensors in high temperatures (+50 degrees C) or in dry gas
8. Do not store sensors in an inert gas
9. If sensors do not give similar readings on a dive, then do a diluent flush to confirm the readings
10. To test for current limiting occasionally do an oxygen flush at $\leq 6\text{m}$ or a diluent flush at depth (predicted PPO₂ should be close to the dive setpoint)
11. Only ever shake moisture from cell membranes or carefully use tissue paper, do not use tools/cloths.
12. Keep electrical connections clean.
13. Do not block the holes on a sensors body.
14. Allow the rebreathers temperature to stabilize before calibrating (if it has been in sunlight/cold and has heated up/frozen). Better still calibrate when the absorbent canister has reached its operating temperature.
15. If you get erratic sensor readings (in known gas content) the sensors may be damaged and should be replaced.
16. Replace sensors that have been flooded.
17. Never swap a sensor to another position in the electronics without recalibration.